

SCMX09S304-UG

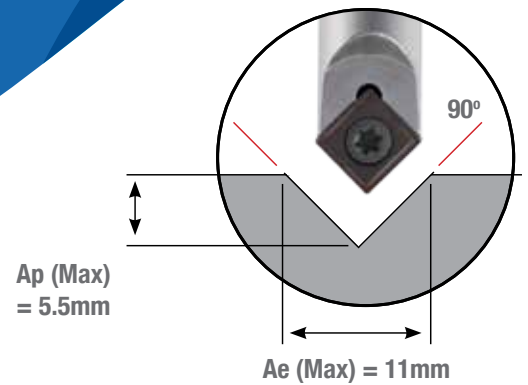

NEW PRODUCT

APPLICATION :

Used on Steels, Cast Irons and Stainless Steel materials
適用於一般鋼材, 鑄鐵和不銹鋼材料之應用

CHAMPLUS⁺

INDEXABLE - MULTIPURPOSE CHAMFERING CUTTER

多功能捨棄式倒角刀

FEATURES 特色

- Multiple Applications with increased performance and higher efficiency
多種應用加工方式, 性能效率更高
- Minimal vibration and Robust Stability
最小的振動和穩健的穩定性
- Tools can be used on CNC Milling Machines / CNC Turning Machines / CNC Turn Mill Centres
適用於CNC銑床/ CNC車床/ CNC車銑複合加工機
- Total 4 Cutting edges for cost effective cutting
共有4個切削刃設計, 經濟高效的切削可降低客戶刀具用量

型號	刃徑	刃長	有效長	全長	柄徑
Article No	Diameter	Cutting Length	Effective Length	OAL	Shank Dia
CH10 - IMC 13100L	13	5.5	29	100	10
CH12 - IMC 13100L	13	5.5	29	100	12
CH16 - IMC 13100L	13	5.5	29	100	16
CH16 - IMC 13150L	13	5.5	29	150	16

切削條件表 / CUTTING CONDITON

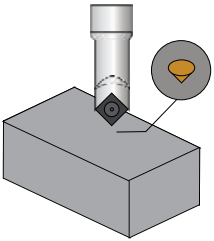
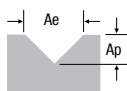
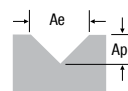
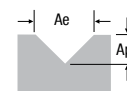
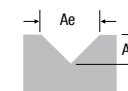
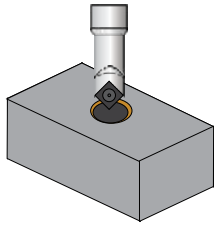
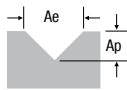
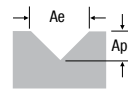
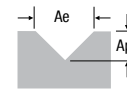
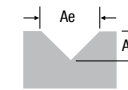
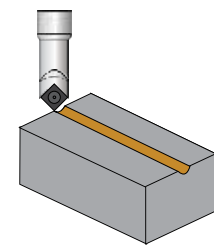
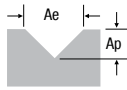
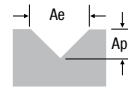
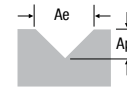
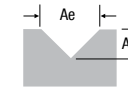
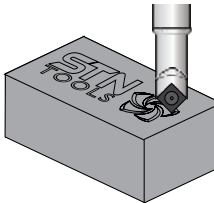
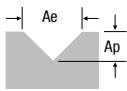
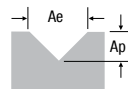
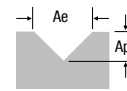
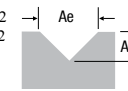
定點加工 / Spotting		定點加工			
	加工材質 Material	碳素鋼 Carbon Steels	合金鋼 Alloy Steels	不鏽鋼 Stainless Steel	調質鋼 Cast Iron
	工件料號 Material Code	S35C,S45C,S50C	SCM,SKT,SKD	SUS304	FC, FCD
	硬度 Hardness	HRC<20	HRC20~30	-	HRC<30
	外徑 / Vc	60 -250 m/min	50 -200 m/min	60 -120 m/min	100 -200 m/min
	外徑 / f	0.05 - 0.10 mm/rev	0.04 - 0.06 mm/rev	0.03 - 0.06 mm/rev	0.05 - 0.10 mm/rev
	切削深度 Depth of Cut (mm)	$A_p \leq 5.5$ $A_e \leq 11$ 	$A_p \leq 5.5$ $A_e \leq 11$ 	$A_p \leq 5.5$ $A_e \leq 11$ 	$A_p \leq 5.5$ $A_e \leq 11$ 
倒角加工 / Countersinking		倒角加工			
	加工材質 Material	碳素鋼 Carbon Steels	合金鋼 Alloy Steels	不鏽鋼 Stainless Steel	調質鋼 Cast Iron
	工件料號 Material Code	S35C,S45C,S50C	SCM,SKT,SKD	SUS304	FC, FCD
	硬度 Hardness	HRC<20	HRC20~30	-	HRC<30
	外徑 / Vc	150 -300 m/min	100 -250 m/min	60 -120 m/min	150 -250 m/min
	外徑 / f	0.15 - 0.22 mm/rev	0.10 - 0.20 mm/rev	0.1 - 0.2 mm/rev	0.15 - 0.25 mm/rev
	切削深度 Depth of Cut (mm)	$A_p \leq 5.5$ $A_e \leq 11$ 	$A_p \leq 5.5$ $A_e \leq 11$ 	$A_p \leq 5.5$ $A_e \leq 11$ 	$A_p \leq 5.5$ $A_e \leq 11$ 
開槽(V)加工 / V - Grooving		開槽(V)加工			
	加工材質 Material	碳素鋼 Carbon Steels	合金鋼 Alloy Steels	不鏽鋼 Stainless Steel	調質鋼 Cast Iron
	工件料號 Material Code	S35C,S45C,S50C	SCM,SKT,SKD	SUS304	FC, FCD
	硬度 Hardness	HRC<20	HRC20~30	-	HRC<30
	外徑 / Vc	60 -250 m/min	50 -200 m/min	60 -120 m/min	100 -200 m/min
	外徑 / f	0.05 - 0.07 mm/rev	0.04 - 0.06 mm/rev	0.03 - 0.06 mm/rev	0.05 - 0.07 mm/rev
	切削深度 Depth of Cut (mm)	$A_p \leq 5.5$ $A_e \leq 11$ 	$A_p \leq 5.5$ $A_e \leq 11$ 	$A_p \leq 5.5$ $A_e \leq 11$ 	$A_p \leq 5.5$ $A_e \leq 11$ 
雕刻加工 / Engraving		雕刻加工			
	加工材質 Material	碳素鋼 Carbon Steels	合金鋼 Alloy Steels	不鏽鋼 Stainless Steel	調質鋼 Cast Iron
	工件料號 Material Code	S35C,S45C,S50C	SCM,SKT,SKD	SUS304	FC, FCD
	硬度 Hardness	HRC<20	HRC20~30	-	HRC<30
	外徑 / Vc	60 -250 m/min	50 -200 m/min	60 -120 m/min	100 -200 m/min
	外徑 / f	0.02 - 0.05 mm/rev	0.02 - 0.03 mm/rev	0.01 - 0.02 mm/rev	0.02 - 0.05 mm/rev
	切削深度 Depth of Cut (mm)	$A_p = A_e \div 2$ $A_e = A_p \times 2$ 	$A_p = A_e \div 2$ $A_e = A_p \times 2$ 	$A_p = A_e \div 2$ $A_e = A_p \times 2$ 	$A_p = A_e \div 2$ $A_e = A_p \times 2$ 

www.stntools.com

D06, 13F-3, No 100, Section 1, Zhong Qing Road, North
District, Taichung 40458, Taiwan (R.O.C.)



Tel: +886-4-22020869
Fax: +886-4-22020892
Email: info@stntools.com